

# WaveSculptor 22 Motor Drive Datasheet

13<sup>th</sup> August 2021

©2021 Prohelion Pty Ltd

Brisbane, Australia

<http://www.prohelion.com>

**TABLE OF CONTENTS**

1	Introduction.....	3
2	DC Bus .....	4
3	Motor Output .....	5
4	Motor Sense .....	6
5	Efficiency.....	7
6	Operating Power & Cooling.....	8
7	Control & Telemetry Interface.....	9
8	Mechanical and environmental .....	10
9	Revision Record .....	11

**WaveSculptor 22 Motor Drive**

PHLN88.003 ver 2

13<sup>th</sup> August 2021**1 INTRODUCTION**

This document describes the specifications, performance and properties of the Prohelion WaveSculptor 22 Motor Controller.

For more details on communications, mechanical positioning and mounting, wiring and precharge, cooling, and installation, please refer to the User's Manual document available on the Prohelion website.

Operating the controller beyond the limits specified in this document will result in the voiding of the controller warranty. Prohelion accepts no responsibility for events caused as a result of operating the controller beyond the limits specified in this document. Note that the specifications in this document are subject to change at any time due to product improvement.

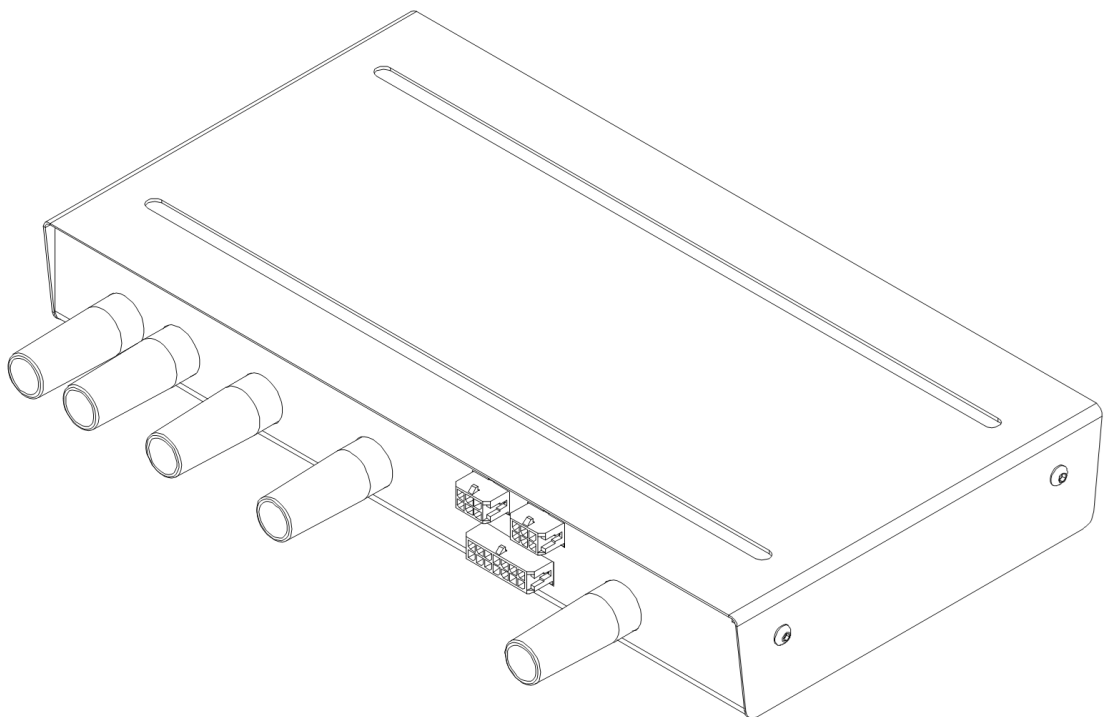

The WaveSculptor22 is built using SN100C lead-free solder from Nihon Superior Co., Japan.

## 2 DC BUS

The DC bus connection provides power to the controller during normal (motoring) operation, and accepts power from the controller during regenerative braking operation. It is expected to be connected to a battery pack through a precharge circuit and a fuse.

Continuous bus voltage minimum:	0	V	(Note 1)
Continuous bus voltage maximum:	165	V	
Instantaneous bus voltage maximum:	175	V	(Note 2)
Instantaneous bus current maximum (drive):	122	A	(Note 3, 4)
Instantaneous bus current maximum (regen):	-122	A	(Note 3, 4)

### Notes:

1. The WaveSculptor control electronics operate from low-voltage DC supplied along the CAN bus cable, not from the high-voltage DC bus. Therefore, the supply to the main power stage (via the DC bus) has no operating minimum voltage.
2. The WaveSculptor uses 200V MOSFETs as the power switching elements. Exceeding this voltage across the device for even a short interval will result in catastrophic failure of the motor controller. The WaveSculptor contains sufficient internal capacitance, and sufficiently rapid detection circuitry, such that it can protect itself against a self-imposed worst-case situation during normal operation. This situation is regenerative braking at full current, at maximum continuous bus voltage, and having the DC bus connection broken or removed. This situation can occur as a result of the DC bus protection contactor opening, the battery fuse blowing, or a loose connection in the vehicle wiring. Operating with higher DC bus voltages than the continuous voltage maximum could result in this self-protection mechanism failing to shut down the controller in time, resulting in the destruction of the controller.
3. The instantaneous current rating of the DC bus is related to the highest power drive situation, which is driving at full motor current and full speed. In this case, the bus current will be  $\sqrt{3} / \sqrt{2} * \text{RMS motor current maximum (100A)}$ , giving a current of 122A DC. The equivalent factors apply for regenerative braking. Although the controller is capable of processing this bus current, the motor impedance (power factor) will limit the current at high speed, therefore limiting the bus current. Modelling of your motor impedance in the drive system should be performed to calculate peak power.
4. The maximum DC bus current can be limited by the WaveSculptor under software control, and is adjustable dynamically via a command on the CAN bus during operation to anywhere between 0 and 100% of full current. This feature can be used to limit the current capability and sizing of battery packs, battery wiring, battery fusing, and contactors.

### 3 MOTOR OUTPUT

The motor output connection provides three-phase power to the motor during normal (motoring) operation and receives power during regenerative braking. It is expected to be connected to a three-phase motor, either an induction or BLDC (permanent magnet) type.

Instantaneous motor current maximum:	100	$A_{rms}$	(Note 5)
Output voltage maximum (at max DC bus):	120	$V_{rms \text{ line-line}}$	
Motor phase inductance minimum:	50	$\mu H$	(Note 6, 8)
Motor resistance minimum:	0	$\Omega$	(Note 7, 8)

Notes:

5. The motor current limit is software controlled and may be limited to lower values via the configuration / setup utility if required.
6. The WaveSculptor requires a minimum amount of inductance in each motor phase to properly regulate current. Not providing this inductance may result in an out-of-regulation condition of the motor current control loop, possibly resulting in an undesired self-protection shutdown, or failure of the controller. Please ensure that both the motor inductance, and any external inductors (if used), are still providing at least the minimum required inductance, even at full rated current, and at elevated temperatures.
7. As long as the minimum inductance per phase requirement is met, the WaveSculptor will regulate current and operate successfully into a shorted connection.
8. The WaveSculptor can report inductance and resistance present on it's output when running the configuration / setup program. This will provide a figure for the complete output circuit, including motor, external inductors (if any), wiring, and connectors. This can be used to verify these values meet the datasheet requirements, but only for low current operation, as the test is performed using a current of approximately 20A. The test will not show problems that are caused by the inductors saturating at high currents.

## 4 MOTOR SENSE

When driving an AC Permanent Magnet motor, the WaveSculptor requires three sensors from the motor to give position feedback at low velocities. When driving an induction motor, the WaveSculptor requires a motor shaft encoder to give velocity feedback. Motor temperature can also be measured for both telemetry data and motor protection, if desired.

Sensor power supply output 1:	5	V	(Note 9)
Sensor power supply output 2:	12	V	(Note 9)
Sensor power supply current maximum:	100	mA	
Sensor power supply isolation:	1000	V	(Note 10)
BLDC motor position sensor input phase offset:	±10	°	(Note 11, 12)
Induction motor encoder resolution minimum:	250	ppr	(Note 13)
NTC Temperature sensor at 25°C:	100	kΩ	(Note 14)

### Notes:

9. The WaveSculptor provides isolated voltage supplies to operate the motor position sensors and motor temperature sensor. These supplies are a regulated 5V and regulated 12V output. Please check with your motor supplier for the acceptable operating voltage of the position sensors used in your motor.
10. The sensor output supply, position inputs, and temperature input have an isolation barrier between them and both the DC bus and the CAN bus voltages.
11. Motor position sensors are only required when driving a AC Permanent Magnet motor. Motor position sensors should be aligned such that the phase angle offset between each sensor's output changing state, and the zero-crossing point of it's appropriate motor phase, is no more than the specified maximum. This implies that the sensors are 120° offset (electrically, per motor pole) from each other under ideal conditions.
12. The polarity and arrangement of the position input signals does not matter. The WaveSculptor detects relative alignment of position signals to motor phases, as well as the polarity of each input, when the Phasorsense algorithm is run during motor controller configuration and setup. The WaveSculptor can store this information for multiple motors, thus allowing motor changes in your vehicle without having to re-run the configuration program. Please refer to the communications and programming Appendix in the User's Manual for more information.
13. The motor shaft encoder is only required when driving a induction motor.
14. The WaveSculptor expects a 100kΩ (at 25°C) NTC thermistor embedded in the motor to detect motor temperature. The thermistor B model constants (available in the thermistor datasheet) can be programmed into the WaveSculptor during configuration / setup to exactly match the temperature response of your thermistor.

5

**EFFICIENCY**

To estimate an operating point efficiency of the WaveSculptor, refer to the efficiency map below. This plot is generated for a DC bus voltage of 160V, assuming a CSIRO 'surface' type wheel motor. Motor efficiencies are not included in the plot.

The efficiency (in percent) is shown using the red lines, and the power being processed by the WaveSculptor (in kW) using the green lines.

In a typical solar car with a mass of 275kg and a wheel radius of 250mm, the maximum plot values of 150rad/s and 120Nm correspond to a maximum speed of 135km/h and an acceleration of 0.16g respectively.

As an example, for a typical highway cruise setting of 20Nm and 100rad/s, the power being processed by the Wavesculptor is just over 2kW, at an efficiency of just over 99%.

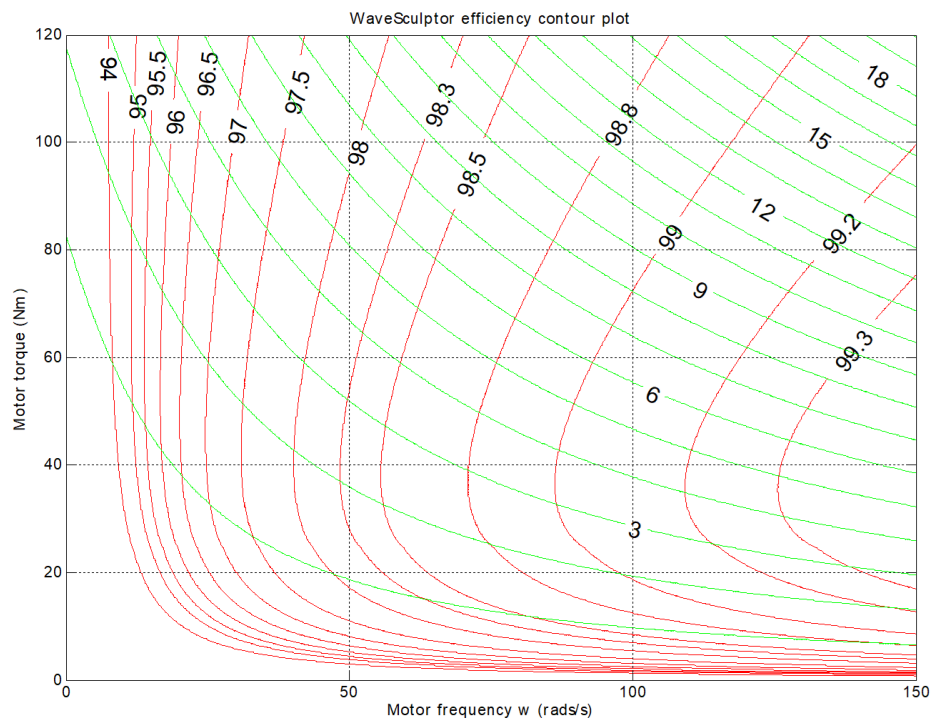

*Illustration 1: Predicted efficiency map of the WaveSculptor controller with a 160V DC bus*

These efficiency maps were generated using an accurate mathematical model of the WaveSculptor’s power stage, with individual loss components confirmed using laboratory testing.

## 6 OPERATING POWER & COOLING

The maximum instantaneous output power from the WaveSculptor is limited by internal hardware restrictions, as detailed in previous sections. However, the continuous power capability of the controller is limited by thermal performance, and is therefore affected by conditions external to the controller such as ambient temperature and cooling system performance.

The WaveSculptor 22 is supplied uncooled, and uses an external customer-supplied heatsink or waterblock to provide cooling for the system. This allows the end-user to optimise the cooling performance, weight, power consumption and drag of their cooling solution.

Please refer to the Cooling section in the User's Manual for calculations regarding cooling capacity and performance.

Maximum instantaneous power output:	20	kVA	(Note 15)
Maximum cold plate design temperature:	70	°C	(Note 16)
Maximum cold plate shutdown temperature:	80	°C	(Note 16)
Maximum continuous power output at 30°C ambient:	20	kVA	(Note 17)
Thermal interface surface length:	250	mm	(Note 18)
Thermal interface surface width:	117	mm	(Note 18)
Thermal interface thread size:	M4		(Note 19)
Thermal interface fastener <b>maximum depth</b> :	14	mm	(Note 19)

Notes:

15. Maximum software current limit multiplied by maximum DC bus voltage limit.
16. The controller is thermally limited to maintain the junction temperature of the main silicon devices below a safe operating point. Design your cooling solution to keep the cold plate of the motor controller below the design temperature. The controller will reduce motor current linearly above this point, derating to 0A output current at the shutdown temperature.
17. With a water-cooled heatsink of 0.6Kcm<sup>2</sup>/W attached to the cold plate, and a water temperature of 30°C, the WaveSculptor22 is capable of operating at its instantaneous power output continuously. This represents the best case cooling solution possible.
18. The base of the WaveSculptor22 is a flat aluminium surface, of these dimensions. A flat area of at least this size should be provided on whatever cooling solution the customer chooses to provide. Please refer to the TRI88.005 Mechanical Assembly document available on the Prohelion website for mounting surface features and dimensions.
19. The WaveSculptor22 provided 8x M4 tapped holes in the base of the product, for use in attaching the motor controller to the customer-provided heatsink or waterblock. **Screws longer than the max depth must not be used**, to avoid damaging internal components in the motor controller.



## 7 CONTROL & TELEMETRY INTERFACE

The WaveSculptor receives commands, and transmits telemetry values, using a CAN bus connection. No other interface is provided. Low-voltage DC power must be provided along the CAN bus cable to operate the control electronics of the WaveSculptor.

CAN bus supply voltage minimum:	9	V	(Note 20)
CAN bus supply voltage maximum:	15	V	(Note 20)
CAN bus supply voltage nominal:	13.8	V	(Note 20)
CAN bus supply power maximum:	4.5	W	
CAN bus data rate maximum:	1000	kbps	(Note 21)
CAN bus isolation:	1000	V	(Note 22)

Notes:

- 20. Prohelion recommends providing the CAN bus supply with 13.8V, using a DC/DC converter and a backup lead-acid battery. This arrangement, when properly implemented, gives a supply that can tolerate failures and still operate the controller successfully for a short period of time.
- 21. The data rate used for CAN bus activity is set during configuration and setup of the controller. Factory default for all Prohelion devices is 500 kbits per second.
- 22. The CAN bus data connection and power supply are isolated from the high-power DC bus to this continuous voltage rating. Please refer to the isolation section in the User's Manual regarding recommended earthing and connection practices.

## 8 MECHANICAL AND ENVIRONMENTAL

The WaveSculptor controller is mounted into position using tapped holes in the cooling surface on the base of the controller. All dimensions in this section are with the controller mounted in position on a horizontal surface. For full details regarding positioning and fixing of the WaveSculptor, please refer to the User's Manual document available on the Prohelion website.

The WaveSculptor controller is splashproof and presents no exposed HV connections able to be touched with a finger or tool. It is not environmentally sealed against major water and dust ingress.

WaveSculptor enclosure length (incl fasteners):	255	mm	(Note 23)
WaveSculptor enclosure width (incl strain relief):	165	mm	(Note 23)
WaveSculptor enclosure height:	35	mm	(Note 23)
WaveSculptor mass:	855	g	(Note 24)
Power cable diameter maximum:	9	mm	(Note 25)
HV electrical terminal thread:	M6		(Note 26)
HV electrical fastening torque maximum:	6	Nm	(Note 26)
Environmental Rating:	IP42		

Notes:

23. Dimensions do not include attached cabling and connectors.
24. Weight includes cable strain relief, and nuts and washers for high current terminal connections.
25. Cable larger than this size may physically fit into the controller, but fitting the bolt crimp lugs over the fasteners in the motor controller may be difficult.
26. The WaveSculptor has permanently fitted threaded studs in the connection area of the main circuit board. The correct fastening hardware to use with these studs is detailed in the User's Manual.

9

**REVISION RECORD**

REV	DATE	CHANGE
1	13 August 2021	Document creation (AJP)