

Battery Management System User's Manual

7 July 2022

©2020 Prohelion Pty Ltd

Brisbane, Australia

<http://www.prohelion.com>

TABLE OF CONTENTS

1	Introduction	4
2	BMS Function	5
3	Warnings	6
4	Terminology	7
5	Cell Management Unit.....	7
5.1	Form Factor.....	7
5.2	Installation	7
5.3	Dimensions	7
5.4	Connectors Overview	7
5.5	Isolation.....	8
5.6	Voltage Rating	8
5.7	Indicators.....	8
5.8	Cell Voltage & Temperature sense Connector	8
6	CMU CAN Bus	9
7	BMS Master Unit.....	9
7.1	Form Factor.....	9
7.2	Dimensions	10
7.3	Connectors Overview	10
7.4	Isolation.....	10
7.5	Indicators.....	10
8	HV Sense	11
8.1	HV Sense Connector	11
8.2	HV Sense Fusing	11
9	Pack Current Sense.....	12
9.1	Shunt Selection	12
9.2	State Of Charge reporting	12
9.3	Overcurrent Shutdown	12
10	Contact Drive / Sense	12
10.1	Contact 12V Supply Connector	13
10.2	Contact Output Connectors	13
11	Precharge	14
11.1	Concept.....	14
11.2	Action	14
11.3	Sequence	14
11.4	Precharge Resistor Selection.....	15
11.5	Caveats	16
12	Trusted Measurements	16
13	Fusing	16

14	Contact Selection	17
15	Operating Thresholds	17
15.1	Over Voltage Threshold.....	17
15.2	Balance Threshold	17
15.3	Balance Threshold Hysteresis	18
15.4	Zero SOC Threshold	18
15.5	Under Voltage Threshold	18
15.6	Over Temperature Threshold	18
16	Charger Control.....	18
17	Operating State.....	19
17.1	Error.....	19
17.2	Idle.....	19
17.3	Enable	20
17.4	Measure	20
17.5	Precharge	20
17.6	Run	20
18	State of Charge (SOC) reporting.....	20
19	Fan/Pump Control.....	20
19.1	Fan/Pump Connectors	21
20	Relay Output.....	21
20.1	Relay Output Connector	21
21	Vehicle CAN Bus	23
21.1	CAN Network Topology.....	23
21.2	CAN Wiring	23
21.3	Vehicle CAN Bus Connectors	23
21.4	CAN Shielding.....	24
21.5	CAN Termination	24
21.6	Communications	24
21.7	Power Supply.....	24
22	Telemetry Viewing Software	24
22.1	BMU Data.....	25
22.2	CMU Data	26
22.3	Command line Options.....	26
23	Additional Documentation.....	27
24	Revision Record	28

1 INTRODUCTION

This document describes the interface, installation, and usage requirements for the Prohelion Battery Management System (BMS).

The BMS provides an easy way to monitor and control an Electric Vehicle battery pack, and can work seamlessly with Prohelion's WaveSculptor motor controllers. It is a mature design with five previous product generations of real-world experience with various types of cells, form factors, and vehicles.

The BMS consists of two components: multiple **Cell Management Units (CMU)**, which measure and control the individual cells in the battery pack; and a single **BMS Master Unit (BMU)** which interfaces between the CMUs and the vehicle, controls precharge and other safety systems, and provides total pack telemetry.

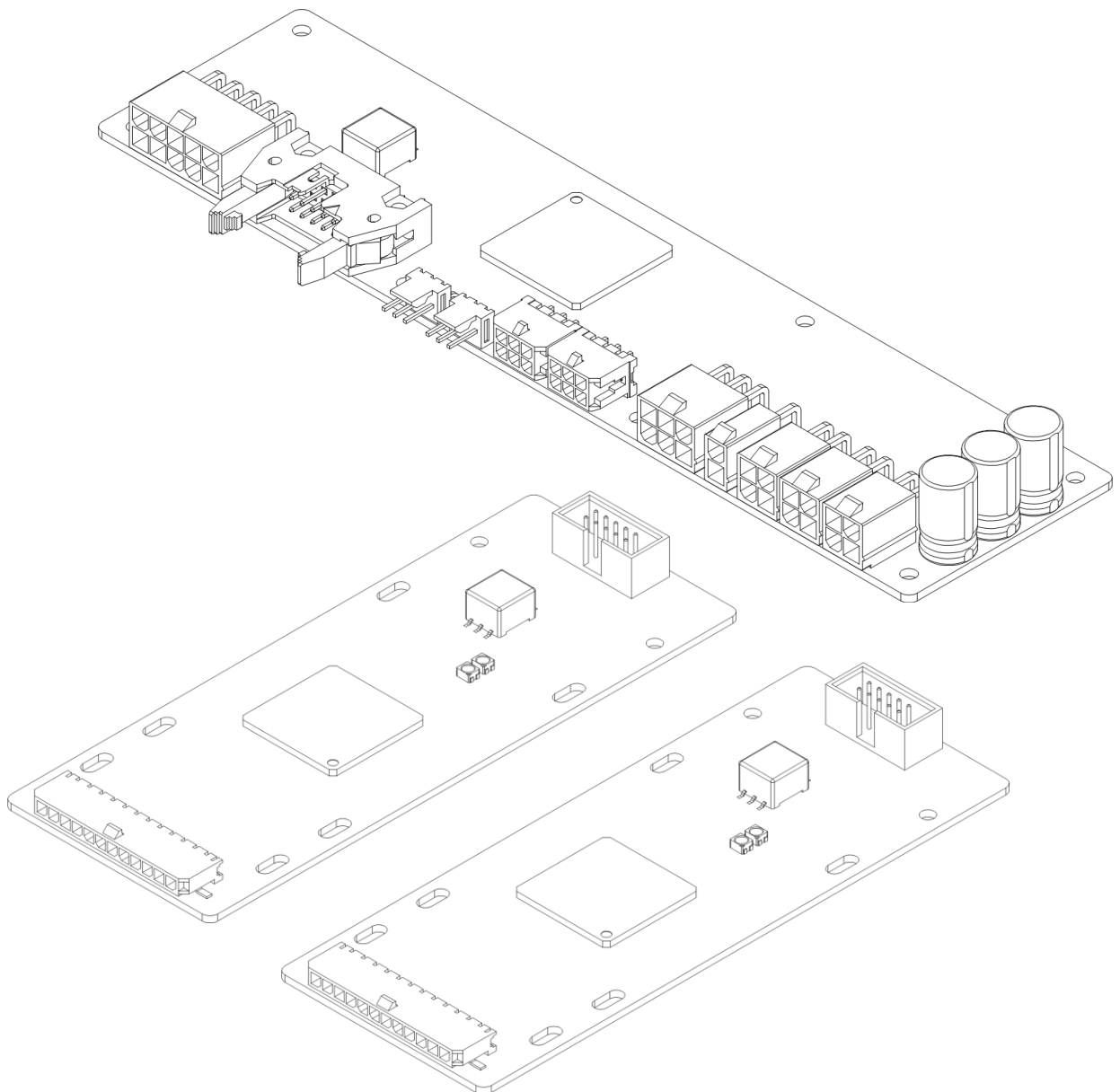

2 BMS FUNCTION

The function of the BMS is threefold, in order of priority:

- *Monitor* cell voltages and temperatures, and act on this information to protect the pack against being operated outside acceptable limits
- *Manage* the cells, to keep them at equal state of charge (SOC)
- *Report* telemetry to the other systems in the vehicle, to allow a graceful reduction in vehicle performance as the battery approaches its limits

The BMS performs these functions by measuring the following parameters:

- Individual cell voltages
- Group cell temperatures
- CMU temperatures
- Total pack voltage
- Total DC bus voltage
- Total pack current
- 12V supply voltages and currents
- Contactor status
- Fan / Pump speeds

To achieve management over the cells and pack, it controls:

- Individual cell bypass (shunt) balance resistors
- Pack contactors, including precharging HV loads
- Battery pack fan / pump
- Battery charger charging current setpoint

Individual cell voltages are the most critical measurement taken by the system, and in the Prohelion BMS are measured using two separate, redundant circuits, each with its own analog circuitry, A/D converter, and reference.

All measurements are cross-checked, and any fault in the system can be identified and reported. This system not only gives reliable and accurate cell voltage measurements, it gives *trusted* measurements.

The Prohelion BMS reports if any measurements are not trustworthy, and this information can be acted on by a higher-level system in the vehicle, for instance by notifying the driver that the vehicle requires servicing.

3

WARNINGS

A properly designed BMS system will protect a battery pack from being operated outside of acceptable limits. However, a poorly implemented system may not provide the expected protection – the Prohelion BMS must be installed in a professional and competent manner to function as designed.

Attention should also be paid to the larger system that the vehicle is part of, especially the systems associated with charging and the infrastructure to support it. As well as using the BMS to protect the pack, additional systems should be provided as backup as part of the charging infrastructure, for instance: fitting of smoke detectors; overcurrent and RCD protection in the AC supply; regular physical checks of charge cabling and connections; regular review of telemetry data for abnormal readings.

This list is not exhaustive, and it is the responsibility of the system designer / installer to conduct their own failure mode analysis and determine what is required.

Working around batteries is DANGEROUS.

Not only are lethal high voltages present, but individual cells can also put out thousands of amps when shorted, for example with a stray wire or dropped tool, throwing out arcs and molten metal.

Check the legal requirements in your jurisdiction for using licensed technicians for this type of work.

Wear eye protection. Use insulated tools. Take extreme caution.

Go slow. Think through every step before doing it.

4 TERMINOLOGY

Cell: A single physical unit, or permanently connected parallel group of units. A parallel group functions electrically as a larger capacity single unit.

Battery: A series-connected group of cells

5 CELL MANAGEMENT UNIT

5.1 FORM FACTOR

The Cell Management Unit (CMU) is supplied as a 1.6mm thickness Printed Circuit Board (PCB), conformally coated, without an enclosure. It is designed to be installed inside the battery box, in a weather-sealed area, along with the cells themselves. This means that all connections to the cells remain inside the battery pack enclosure, simplifying fusing and wiring installation requirements.

5.2 INSTALLATION

The CMU should be mounted to a flat surface, using at least four M3 fasteners, with the supplied piece of insulation material between the CMU and the surface. The CMU will operate at a much lower temperature when balancing if the mounting surface is a thermally conductive material such as aluminium or steel, and it is strongly recommended to install the CMUs on a surface such as this. CMUs should not be stacked together, as they will overheat.

For a professional installation, press-fit M3 studs (eg PEM FHS-M3-10) can be installed in the wall of the box prior to fitting the CMUs. The insulating sheet and CMU are then installed over the studs, and retained in place with Nyloc nuts.

Wiring should be appropriately strain relieved to withstand the vibration typically found in an automotive environment – do not support the weight of the wiring loom solely from the connectors on the CMU.

5.3 DIMENSIONS

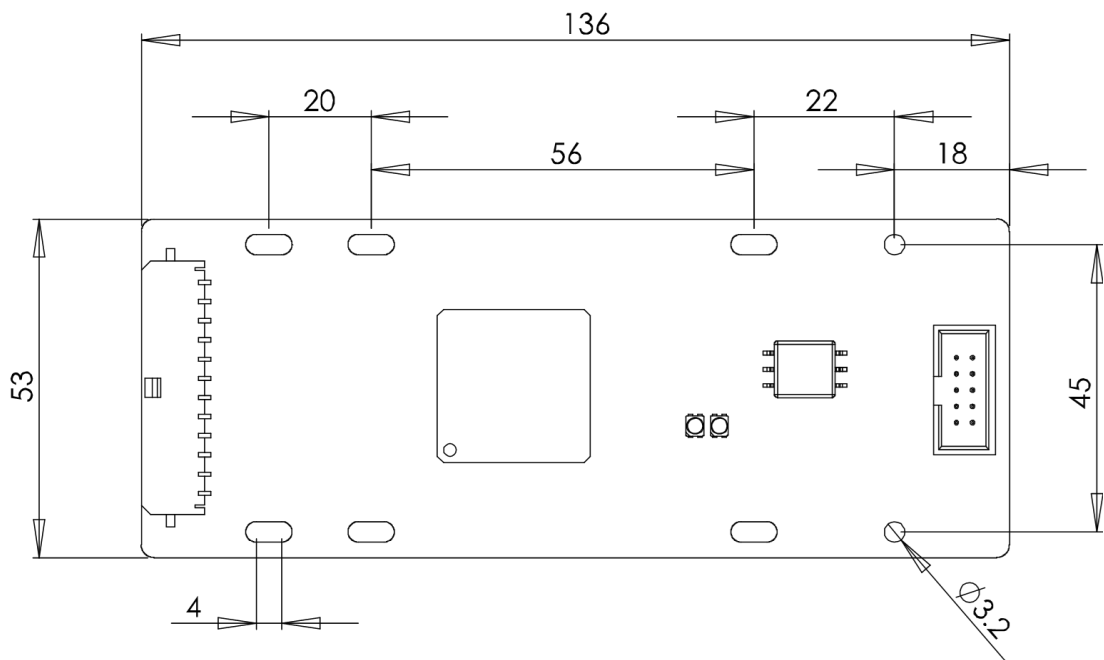

5.4 CONNECTORS OVERVIEW

The following illustration shows the connections and indicators on the CMU:

Battery Management System

PHLN67.011 ver 1
7 July 2022

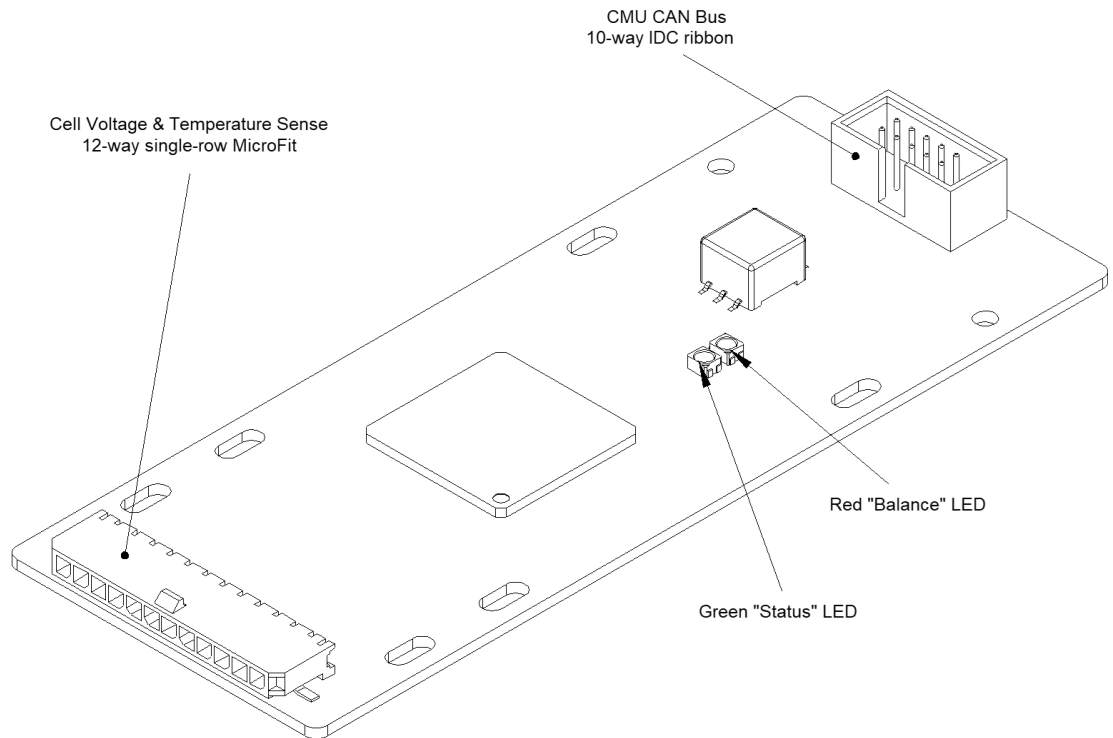

5.5 ISOLATION

The CMU is isolated from the CMU CAN bus, and therefore from the vehicle chassis and other CMUs, with an isolation barrier rated for 1000V DC. This allows the HV battery pack to be fully floating from the vehicle chassis, as is required by most EV construction standards (eg NCOP14 in Australia).

This isolation barrier rating is only valid if the correct insulation material is installed between the CMU and the surface it is mounted on.

As the CMU CAN bus operates relative to the vehicle chassis, the CMU CAN ribbon cable should be kept isolated from the cells and cell sense wiring with a rating of at least the full voltage of the battery pack.

5.6 VOLTAGE RATING

The CMU voltage sense inputs are rated for a maximum of 5V per cell. Therefore, there must not be any breaks in the main battery string (from contactors, fuses, or service links) among the set of up to eight cells that are measured by a CMU, as a high voltage may be seen across this break when it is open, and destroy the CMU. Any breaks must be located between CMUs.

5.7 INDICATORS

The green LED on the CMU flashes to indicate that the CMU has power (via the CMU CAN bus) and the microcontroller is operating.

The red LED illuminates when any of the eight cells are balancing. This LED illuminating is not a fault condition.

5.8 CELL VOLTAGE & TEMPERATURE SENSE CONNECTOR

The connector used for the Cell Voltage Sense is a 12-way single-row 3mm pitch Molex MicroFit connector. The pinout is shown below, as viewed from the wire side – as you would look at it while inserting crimps. The colours shown match those used in the recommended cable.

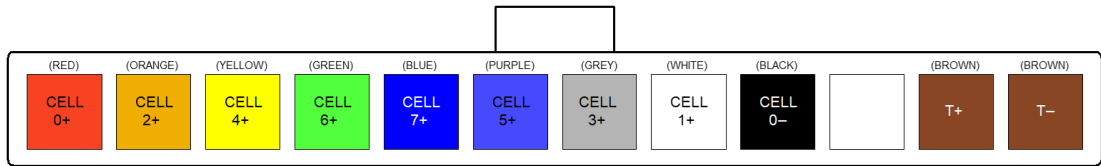

Please refer to the associated Assembly Procedure document TRI67.006 for detailed procedures on making the cell sense wiring harness.

5.8.1 Temperature Sensor

The recommended cell temperature sensor to use is a Murata 10k NTC bead type thermistor (NXFT15XH103FA2B100) with 100mm leads. The thermistor should be attached to a part of the cell that is a good representation of the internal temperature, such as a cell terminal (Care MUST be taken that the sensor is appropriately insulated from the terminal).

6 CMU CAN BUS

The CMUs and BMU communicate via CAN bus at a fixed 125kbit/s rate, running over standard 1.27mm pitch 10-way IDC ribbon cable.

The BMU supplies 12V power to the CMUs along this cable.

As a CAN bus, this cable requires termination of the CAN-H and CAN-L signals together at both ends of the network. Use the supplied CMU CAN termination boards to do this.

Use a single length of cable to join all CMUs, the BMU, and both termination resistors together. This can easily be achieved by crimping on a standard 10-way IDC crimp as the cable passes each device.

Pin 1 on each device is indicated by an arrow and the numeral '1' on the PCB, and/or an arrow moulded in the connector.

Make sure that the ribbon is oriented correctly on all devices: Pin 1 should join to Pin 1 on every other device, and should also be the polarity indication on the ribbon cable, usually a red stripe.

The CMU CAN bus cable is electrically connected to vehicle ground at the BMU, and therefore must be kept physically separated from any battery or other HV connections to at least the maximum voltage rating of the pack.

7 BMS MASTER UNIT

7.1 FORM FACTOR

The BMS Master Unit (BMU) is supplied as a 1.6mm thickness Printed Circuit Board (PCB), conformally coated, without an enclosure. It is designed to be installed inside the battery box, in a weather-sealed area, along with the cells themselves. This means that all connections to the pack remain inside the battery pack enclosure, simplifying fusing and wiring installation requirements.

The BMU should be mounted to a flat surface, using 7x M3 standoffs, of sufficient length to allow the appropriate clearance distance between the components on the PCB and the mounting surface. Use of an insulation material layer may allow a lower-profile mounting. This distance will be determined by the maximum operating voltage of the pack, required isolation voltage rating, and regulatory creepage and clearance distances.

All connections to the BMU are along one edge, simplifying wire routing inside your battery enclosure. Wiring should be appropriately strain relieved to withstand the vibration typically found in an automotive environment – do not support the weight of the wiring loom solely from

the connectors on the BMU.

7.2 DIMENSIONS

The BMU PCB size and mounting holes are shown below. Dimensions in mm.

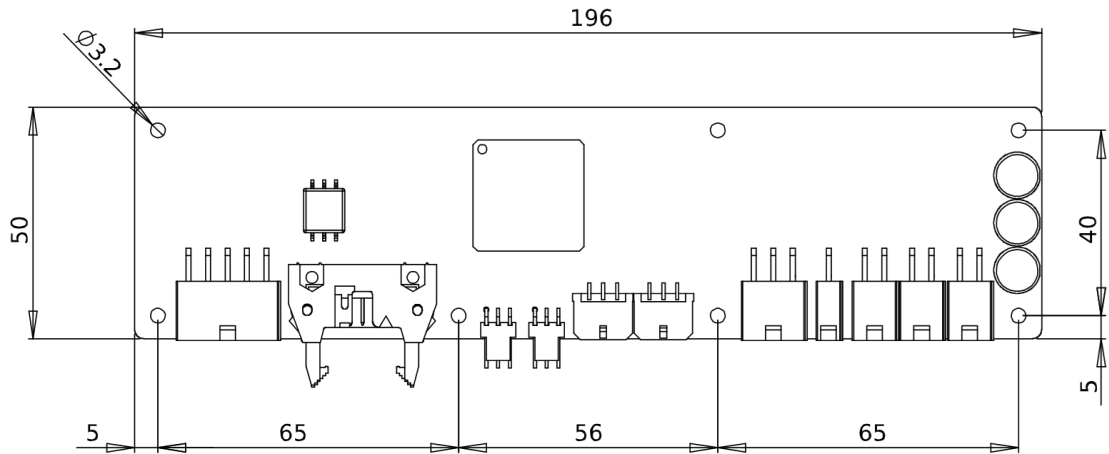

7.3 CONNECTORS OVERVIEW

The following illustration shows the connections on the BMU:

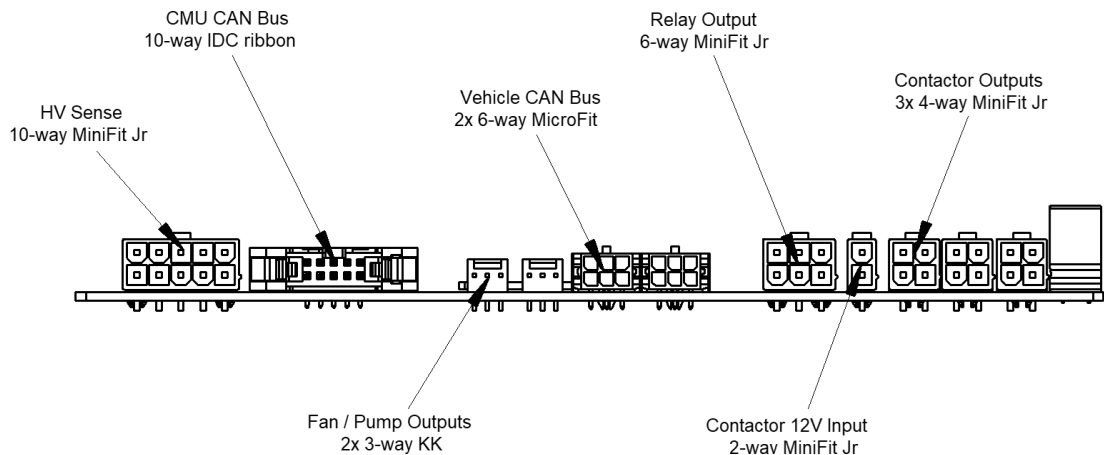

Refer to the relevant sections of this document for more details on the pinout and wiring for each connector.

7.4 ISOLATION

The HV Sense connection is isolated from the remainder of the BMU with an isolation barrier rated for 1000V DC. This allows the HV battery pack to be fully floating from the vehicle chassis, as is required by most EV construction standards (eg NCOP14 in Australia).

The remainder of the BMU operates relative to the GND supplied along the vehicle CAN bus connection, and this must be tied to the vehicle chassis at some point in the system.

7.5 INDICATORS

The output status of the three contactor drives, fan outputs, and CMU CAN bus power are all indicated with green LEDs at the edge of the BMU adjacent to the relevant connector.

Other indications and faults can be observed using the Windows PC software via the CAN-Ethernet bridge, or by any other device on the CAN bus that is programmed to receive status messages from the BMS.

8 HV SENSE

The HV Sense connector allows the BMU to measure the total pack voltage (pack side of the contactors), total DC bus voltage (vehicle side of the contactors), and total pack current flow. This information is used to control precharge and pack safety, and to calculate pack Ah usage and SOC.

The HV Sense connector and associated electronics are isolated from the remainder of the BMU. Take care when routing wiring around this connector to maintain good isolation between it and the rest of the vehicle system.

Wire the Vehicle HV+ and Battery HV+ sense wires to their respective sides of Contactor 2 in the positive rail. Wire the Battery HV- and Shunt sense wires to their respective sides of the current shunt in the negative rail. Refer to the BMS wiring diagram in the Appendix for more details.

Please note that this sense wiring must be rated for the full pack voltage, although it is low current so a small gauge wire can be used. Check the relevant wiring standards regarding wire rating and colours, for example NCOP14 (in Australia) specifies Orange wire for all battery pack and other HV system wiring.

The Battery HV- and Shunt sense wires should be twisted together to minimise noise pickup between the BMU and the shunt. It is suggested to have these wires no longer than 300-400mm.

8.1 HV SENSE CONNECTOR

The connector used for the HV Sense is a 10-way 4.2mm pitch Molex MiniFit Jr connector. The pinout is shown below, as viewed from the wire side – as you would look at it while inserting crimps. The colours shown match those recommended in most EV wiring standards for HV DC wiring.

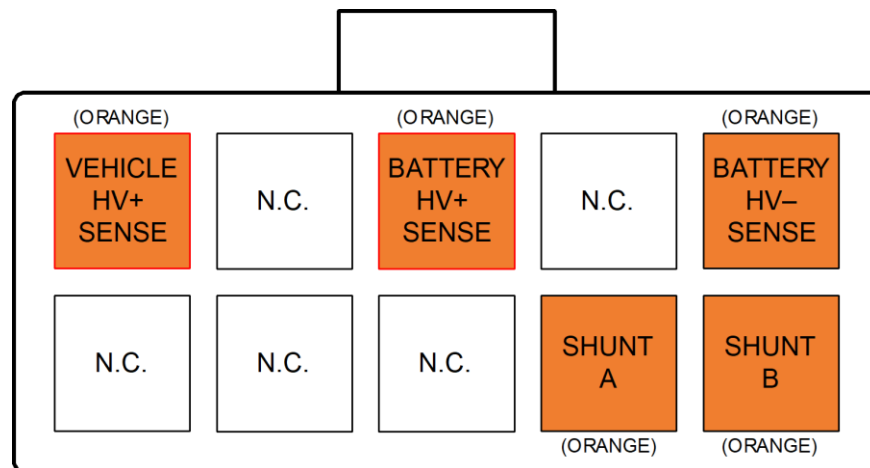

The sense points are as follows:

- Vehicle HV+ Sense Vehicle side of Contactor 2
- Battery HV+ Sense Battery side of Contactor 2
- Battery HV- Sense Battery side of 25mV Shunt
- Shunt A Vehicle side of 25mV Shunt
- Shunt B Battery side of 25mV Shunt

8.2 HV SENSE FUSING

All HV Sense connections should be fused with an appropriately rated fuse for the type of wire

used for the sense connection. This fuse should be low current (since the sense wiring uses small wires) and rated for the full DC pack voltage. The fuse should be located towards the supply end of the sense wiring.

9 PACK CURRENT SENSE

The BMU provides a mechanism for measuring pack current using a resistive shunt. This is preferred over hall-effect based sensors as it provides much lower drift, allowing more accurate State of Charge (SOC) integration calculation.

The shunt **must be** located in the **Battery HV-** connection of the pack, as shown in the BMS wiring diagram in the Appendix.

9.1 SHUNT SELECTION

The BMU Shunt Sense input has a full-scale range of $\pm 25\text{mV}$, relative to the Battery HV- Sense input. This allows the use of a standard 50mV shunt running at half its rated current to minimise heat buildup and thermal drift effects, since it will be installed inside the battery pack.

Choose a full-scale range slightly over the expected maximum battery current. As an example, a Prohelion WaveSculptor200 motor controller driving an induction motor may have an expected maximum power consumption of 90kW. At a 400V battery voltage, this is 225A. Choose a full scale of 250A to allow some headroom on the measurement. Since we wish to use a standard 50mV shunt at half rating, you would therefore select a 500A/50mV shunt.

The value of the shunt can be set in the user-interface software.

9.2 STATE OF CHARGE REPORTING

The BMU takes readings of the shunt current using a high-accuracy front-end circuit and 24-bit A/D converter. It integrates these readings to accumulate an Ah consumption for the pack.

The Ah accumulation is used in conjunction with the user-settable pack capacity value to calculate a SOC in percent. Both Ah and percent are reported on the CAN bus.

The SOC reading is reset to 'full' when the first bypass shunt has activated during a charge cycle. At this point the "Balance SOC" telemetry value begins incrementing, halting when all bypass shunts are active. This "Balance SOC" telemetry value therefore shows the amount of imbalance between cells that has been corrected during the current charging session.

9.3 OVERCURRENT SHUTDOWN

The BMU has the capability to shut down the pack by opening the contactors if the pack current exceeds a fixed threshold. This function is not currently implemented in the default firmware, but will be added at a later date.

10 CONTACTOR DRIVE / SENSE

The BMU provides three outputs for driving HV contactors with 12V coils. At a minimum Contactors 1 & 2 are required for pack safety, although this option still presents a shock hazard (via the precharge resistor) in a single-fault situation to the rest of the system. A professional design will use all three contactors.

The contactors are energised in sequence (1, 3, 2) during precharge, and de-energised when shutting down the system both under user command and due to a fault being detected by the BMS. The BMU operates the contactors to protect the cells above all other priorities.

Each contactor output connector also has pins for feedback from contactors with auxilliary sense contacts. These can be used by the BMU to detect failed contactors, both failed open or welded shut. Do not connect these pins to anything other than auxilliary contact output terminals – they are not rated for anything more than the 12V supplied by the BMU.

Refer to the BMS datasheet for continuous and peak current and voltage ratings of the contactor drive outputs. Contactors without integrated electronics must have a diode fitted across their coil terminals to limit flyback voltage at turn-off.

10.1 CONTACTOR 12V SUPPLY CONNECTOR

The connector used for the Contactor 12V supply input is a 2-way 4.2mm pitch Molex MiniFit Jr connector. The pinout is shown below, as viewed from the wire side – as you would look at it while inserting crimps.

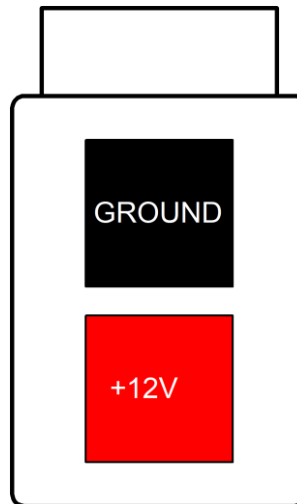

This connection should be wired to the vehicle 12V DC supply via the emergency stop switch (if fitted), the G-force impact switch, an optional HV disable switch, and a fuse. It requires a low impedance connection to the vehicle battery, since most contactors draw a large current inrush during turn-on, and a poor connection will result in contactor chattering and/or precharge fault trips.

This connection draws no current when the BMS is in the off state, and does not have to be routed via the ignition key. Connecting it to a permanent source of power (rather than via the ignition key) allows the BMS to operate the contactors without the ignition key switched on, for example during charging.

10.2 CONTACTOR OUTPUT CONNECTORS

The connectors used for the Contactor drive outputs are a 4-way 4.2mm pitch Molex MiniFit Jr connector. The pinout is shown below, as viewed from the wire side – as you would look at it while inserting crimps. The colours shown match those used by the Gigavac GX11 and GX12 family of contactors.

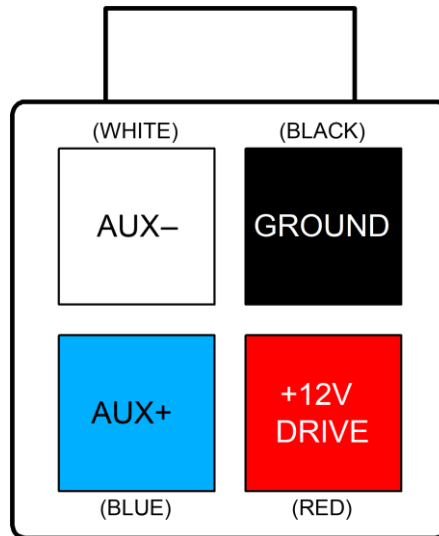

11 PRECHARGE

11.1 CONCEPT

Loads such as motor controllers (inverters), DC/DC converters, and other high-voltage, high-power electronics contain capacitors across the DC bus. If these are suddenly connected to the battery pack by closing a contactor or switch, then there will be a very large inrush current (thousands of Amps) followed by a voltage surge due to the battery and cabling inductance. This inrush current will damage the devices and weld contacts together, and the voltage surge can also cause components to fail.

Precharging the capacitors in the various devices solves these problems. This can be done by first connecting the loads to the battery through a resistor, so that the current into the capacitors is limited to a few amps. The voltage on the capacitors will then rise in a controlled manner, and when it is close to the battery voltage the main contactor can be closed to directly connect everything together.

11.2 ACTION

The BMU initiates a precharge sequence when commanded to do so from the EV Driver Controls. There are two conditions that begin precharge: the ignition key moving to the *start* position from the *run* position; and the *fuel door* being opened for charging.

Either closing the *fuel door*, or moving the key to no longer be in Ignition *run* position will shut down the system and open the contactors to make the system safe.

The BMU can also be set to run in “Standalone Operation” mode, where it will precharge as soon as it measures an acceptable voltage on the 12V contactor power input. This mode would normally be used in remote area power installations and similar applications, not in vehicles.

11.3 SEQUENCE

The precharge sequence is as follows:

1. Contactor 1 energises to connect Pack- to the vehicle
2. Contactor 3 energises to connect Pack+ to the precharge resistor, and allow the BMU to take pack voltage measurements.
3. The capacitors in the devices in the vehicle precharge through the precharge resistor that is in parallel with Contactor 2

4. When the pack voltage and the DC bus voltage are within tolerance then Contactor 2 is energised to complete the high-current circuit
5. The BMU is now in "Run" mode, and does the following:
 - reports this fact on the CAN bus
 - activates the status relay output (which can be used to enable the DC/DC converter)
 - turns on the pack fan outputs

11.4 PRECHARGE RESISTOR SELECTION

Selection of the external precharge resistor is critical for correct and long-term reliable operation of the precharge circuit. A judgement must be made by the designer of the vehicle power system to the tradeoff between resistor size, cost and weight, and expected precharge time. A slower time can use a smaller, cheaper resistor, but taking too long to precharge will be annoying to the end user of the vehicle. An aluminium-cased wirewound resistor is the most commonly chosen type of resistor.

As an example, the calculations for a typical EV system are shown as follows:

System battery voltage maximum = **450V**

Motor controller (Prohelion Wavesculptor 200) capacitance = **800 μ F**

Chosen precharge current = **1A**

Therefore, the minimum resistance (fastest precharge) will be $450V / 1A = 450$ Ohms. Choose **470 Ohms** as the next highest common value. Peak power dissipation in the resistor is therefore $450V^2/470R = 430W$.

The expected precharge time is given by the time constant $TAU = R$ (Ohms) * C (Farads), where the voltage on the capacitor should change by 63% of the difference each TAU time interval. Precharge should be within 95% of the initial value within 4 TAU, and to 99% within 5 TAU intervals, as an exponential decay. For the example system, $TAU = 376ms$, so the expected precharge time of 4 TAU = **1.5 seconds**.

Choosing a $>500W$ resistor is unnecessary, as this rating is only needed for a short amount of time during normal operation. However, the resistor cannot be too small, as if a fault situation occurs, such as a short circuit in the motor controller, then this power will be dissipated continuously for the entire expected precharge time, until the precharge controller realises that precharging has not occurred properly and goes into an error state. For safety, the resistor in the example system should be chosen to tolerate a one-off event, starting at the expected maximum ambient temperature, of 430W for 1.5 seconds.

Searching through available off-the-shelf options from Digikey, the RH series from Vishay is chosen as a likely candidate. According to the datasheet located at <http://www.vishay.com/docs/50013/rh.pdf>, for short time overloads, a power rating of 12x the nominal power is acceptable for a 2 second duration. Using a 50W resistor, this equates to an overload rating of 600W, starting at an ambient of 25°C.

Therefore, this 50W resistor is acceptable for the external resistor in this application based on maximum fault power.

During normal operation, the capacitors contain a charge of 0.36C, giving an energy storage of **81 Joules**. Note that this is a lethal amount of energy. During an RC precharge type event, the same amount of energy that is eventually stored in the capacitor is also dissipated in the resistor.

If not mounted on any additional thermal mass, and assuming that 20g of the resistor's total mass is aluminium (specific heat = 0.897 J/g°C), 81 Joules will give a temperature rise of $\Delta T = Q/mc = 4.5^\circ C$, also well within limits. During a fault situation, where 430W is being dissipated in the resistor, the same thermal calculation shows a temperature rise of 48°C above

the starting temperature. This also is within limits.

The maximum acceptable operating voltage for the 50W resistor is 1285V, so our maximum of 450V is also within limits.

Therefore, a **470 ohm, 50W, RH series wirewound aluminium resistor** would be a suitable choice of external resistor for this application of precharging **800uF to 450V in 1.5 seconds**. Other devices on the HV bus such as DC/DC converters and battery chargers will add significant extra capacitance, and must be factored into these calculations.

Note that the BMS must be programmed with the correct timeout value, so as it knows what the expected precharge time is. If this is not done, then the precharge controller will either expect precharge to have finished when it has not, resulting in an error state, or it will expect precharge to take much longer than it really does, resulting in a potential overload and a fire in the external resistor if there is a system fault.

11.5

CAVEATS

Be aware that loads that draw current *during* precharge will cause the precharge sequence to fail and/or the precharge resistor to overheat. This is because the current drawn by the load will slow or possibly prevent the output voltage from rising, meaning precharge never completes in the expected time.

The typical load that causes this problem is the DC/DC converter used to charge the 12V auxilliary battery.

This problem can be avoided by using the relay output on the BMU to control an "enable" input on the problematic loads once precharge has completed and the BMU is in "Run" mode. By default, this relay activates in this manner.

12

TRUSTED MEASUREMENTS

The CMUs measure their cell voltages using two separate front-end circuits, A/D converters, and voltage references. One channel records with a high resolution 24-bit converter at a slow 2 Hz rate. The other channel uses a mid resolution 12-bit converter running at several kHz. These are cross-checked against each other to verify that the CMU is functioning correctly and that the cell voltage measurement can be trusted.

Measurements reported on the CAN bus telemetry come from the high resolution channel.

Measurements where the two channels do not agree are flagged as untrusted. If any cells report an untrusted measurement, the BMU will report a TRUST error on the CAN bus. This is not treated as a fatal error, and will not result in a pack shutdown.

The threshold where a trust error is generated is set in the BMU config, and is currently factory set to 100mV.

Please note that due to the different response rates of the two A/D converters, it is possible to get a trust error briefly during sharp voltage transients on the cells, for instance during rapid acceleration or regen braking events. Whatever higher-level vehicle system is handling BMS telemetry and user interface should be programmed to ignore trust errors that are present for less than some period (eg 500ms) of time.

13

FUSING

The battery pack must be fused in each physical pack section with a fuse rated for at least the full DC pack voltage. Note that it must be a DC rated fuse.

Selection of fuse type and current rating is beyond the scope of this document, as it depends on expected load profile and duration, cable sizing and temperature rating, cable installation methods, and short-circuit rating of the pack, among other factors.

14 CONTACTOR SELECTION

The three contactors used to break the HV DC connections must be appropriately rated for the currents and voltages seen during both normal use and during fault situations. Typical parts used in automotive sized packs are the Tyco EV200 or the Gigavac GX11 or GX12 series. Selection of these parts is beyond the scope of this document.

15 OPERATING THRESHOLDS

There are six user-settable thresholds that control the operation of the BMS. These should be set based on the maximum acceptable limits for the cells used in the battery pack, along with reference to the charge/discharge curves for selecting the balancing points.

These operating points can be programmed into the BMU over the CAN bus using the BMS Setup software and a Prohelion CAN-Ethernet bridge. Settings that are required at the CMUs are passed to them from the BMU when the system starts.

The SOC vs Voltage curve for a typical Lithium chemistry cell is shown below, along with the location of the various thresholds.

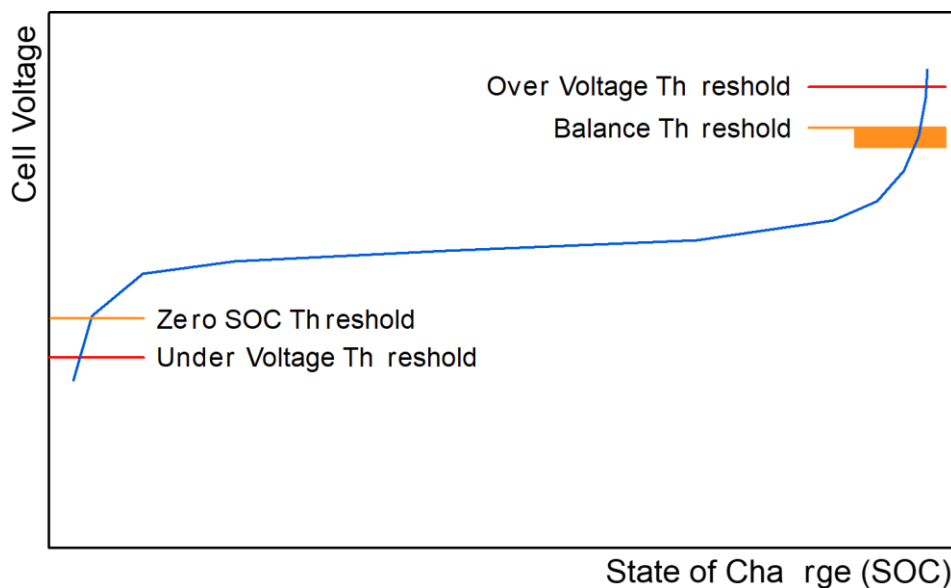

15.1 **OVER VOLTAGE THRESHOLD**

This voltage should be set to the maximum acceptable voltage for the cell. If it is ever exceeded, then the BMS will move to the Error state and open the contactors immediately to protect the pack.

15.2 **BALANCE THRESHOLD**

This voltage is the target setpoint for the charging control algorithm, and will be the voltage that the cells are charged to in normal operation. It should be chosen to be part-way up the 'knee' in the voltage charge curve, so that the cells can be easily seen to be at different SOC and therefore balanced accurately.

Choosing this number to be higher (closer towards the Over Voltage Threshold) will give a slightly increased useable capacity of the pack, but will make it more likely that sudden regen braking will push a cell above the Over Voltage Threshold and shut down the system without warning. Pushing the usual charge voltage to the maximum rating of the cell may also reduce cell cycle life – refer to the cell datasheet for specific information on this aspect, as it is highly dependant on cell chemistry and manufacturing techniques.

When any cell exceeds this voltage, the cell balance (shunt) resistor for that cell is switched on, and begins to discharge that cell at approximately 250mA. The shunt resistor remains switched on until the cell falls below the Balance Threshold by the Balance Threshold Hysteresis value.

15.3 BALANCE THRESHOLD HYSTERESIS

This voltage determines the hysteresis used to control the balance resistors.

If using CMUs made after January 2013, it should be set to around 5mV, as the firmware in the newer CMUs turns off the shunt resistors while taking voltage measurements to eliminate errors caused by the resistance of the sense wiring.

If using older CMUs, it should be set to around 50mV for a typical pack, to allow for the voltage drop in the sense wiring, connections, and cell impedance when 250mA of balance current is flowing. This will be installation dependent.

Setting it too low will cause oscillations in the balance resistor switching and possibly erroneous voltage measurement reporting.

Setting it too high will give a wide band of voltage that various cells are balanced to, giving a less than optimally balanced pack and slightly reduced pack capacity.

15.4 ZERO SOC THRESHOLD

This voltage should be set to the point where the cells are considered fully discharged during normal operation. It will be along the lower 'knee' in the charge curve. When a cell goes below this threshold, the BMU reports SOC as 0%. It is also the target minimum voltage used by motor controllers and other devices to not exceed during operation.

15.5 UNDER VOLTAGE THRESHOLD

This voltage should be set to the minimum acceptable voltage for the cell. If any cell voltage falls below this point, then the BMS will move to the Error state and open the contactors immediately to protect the pack.

15.6 OVER TEMPERATURE THRESHOLD

This temperature should be set to the maximum acceptable operating temperature for the cell. If it is ever exceeded, then the BMS will move to the Error state and open the contactors immediately to protect the pack.

16 CHARGER CONTROL

To charge and balance the pack correctly the BMS must be able to control the charging current in a continuous manner. Therefore, a charger that is able to be controlled remotely is required. Battery management systems and chargers that use on/off control will result in slow and/or poor balancing of cells.

Suitable chargers that the BMS currently supports are the Brusa NLG series, and the TC Charger range with CAN-bus option. Please contact Prohelion regarding support for other types of chargers.

The BMU runs a PID control loop based on maximum individual cell voltage, with the aim of raising it up to the *Balance Threshold* voltage. It will issue current setpoint commands to the charger to achieve this goal.

This control strategy results in the minimum possible charge time, as the charger will be ramped up to maximum current rapidly, and stay there until the maximum cell reaches the target voltage at the end of the 'constant current' portion of the charge cycle. At this point, charge current will be gradually ramped down, at whatever rate is necessary to keep the maximum cell at the target and adsorbing as quickly as possible – the 'constant voltage' portion of the charge cycle. Therefore, it does not matter at what rate the cell is adsorbing charge, the control loop will keep it at the optimal amount at all times.

As the maximum cell reaches 100% SOC, the charging current will have been gradually reduced down until it matches the balance current of $\sim 250\text{mA}$. At this point, the maximum cell will be at the target voltage, held at that point by the balance resistor, and lower cells in the pack will be rising at the rate governed by the 250mA charge.

When the *minimum* cell reaches the target voltage, then all cells are in balance, and the pack is at 100% SOC. This time difference between maximum and minimum cells reaching the target voltage is usually only a few minutes for a well-balanced battery pack. Therefore, the power wasted in the balance resistors during this time is a trivial percentage of the total charge energy.

Note that the very first balance may take considerable time if the cells are grossly out of balance. Worst-case time is the Ah capacity of the cells divided by the 250mA balance rate divided by the out-of-balance percentage, eg $90\text{Ah} / 0.25\text{A} / 20\% = 72$ hours.

17 OPERATING STATE

The BMS can be in any one of six states, depending on operating conditions, commands, and errors. The states are reported on the CAN bus, and shown in the BMS Viewer software. The states are, in the most commonly seen sequence:

- Error
- Idle
- Enable
- Measure
- Precharge
- Run

States transition from one to another based on various thresholds and timers, and on user commands from the Prohelion EV Driver Controls via the CAN bus, as detailed in the following sections.

17.1 **ERROR**

The BMS is in the Error state if any of the following conditions are true:

- The 12V contactor supply is not present or is undervoltage
- Any cell Over Voltage
- Any cell Under Voltage
- Any cell Over Temperature
- Any CMU communications packet is overdue (CMU timeout)
- Packets from the EV driver controls are overdue (vehicle timeout)
- Missing CMU or cell
- Extra CMU or cell
- Contactor feedback mismatch to the commanded state of the contactor

In the Error state, all contactors are switched off to isolate the pack. The relay and fan outputs are also switched off.

If all errors are removed, then the BMS will transition to the Idle state if the ignition key is switched to the accessories position and the *fuel door* is closed. It requires this active user intervention to move to Idle, and will otherwise remain in the Error state.

17.2 **IDLE**

In the Idle state, the BMS waits for a command from the EV driver controls. All contactors are

switched off. The relay output and fans are also off.

If the ignition key is switched from the *run* position to the *start* position, or the *fuel door* is opened, then the BMS transitions to the Enable state and begins a precharge sequence.

17.3 ENABLE

Contactors 1 and 2 are switched on, to connect the Pack- connection to the vehicle. After a short time to allow the inrush current from the contactors switching to subside on the 12V supply, the BMS transitions to the Measure state.

17.4 MEASURE

Contactors 3 and 4 are also switched on, to connect the Pack+ connection to the vehicle via the precharge resistor. The vehicle will begin precharging.

After a short time to allow the total pack voltage measurement to stabilise, and the 12V current inrush from the contactors switching to subside, the BMS transitions to the Precharge state.

17.5 PRECHARGE

The load will now be precharging. The BMS begins a timeout (error) counter (2000ms by default), to avoid a fault situation overheating the precharge resistor, and also begins comparing the total pack voltage and DC bus voltage measurements.

When they match within a the *precharge voltage threshold* (20V by default), precharge is regarded as complete and the BMS transitions to the Run state.

17.6 RUN

Contactors 5 and 6 are also switched on, to directly connect the Pack+ connection to the load. The relay and fan outputs are switched on.

If the ignition key is switched away from the *run* position (back to *accessories*) or the *fuel door* is closed, then the BMS transitions to the Idle state.

18 STATE OF CHARGE (SOC) REPORTING

The BMS reports State of Charge (SOC) based on integrating the pack current (coulomb counting).

The SOC is calculated in Amp-Hours (Ah), based on the user-set scale value for the 25mV shunt. The Ah is then also calculated to a percentage, based on the user-set value for total pack capacity.

Ah are set to zero when the first cell reaches the balance threshold while charging for the first time. It then counts up to indicate Ah drawn from the pack. It will count back down towards zero when the pack is recharged.

A second telemetry value is also reported, the *Balance SOC*. This value begins counting when the first cell reaches the balance threshold during charging, and continues to count until the last cell has reached the balance threshold. This gives an accurate value for the amount of imbalance in the battery pack that was corrected during this charging session. Logging this value in a higher-level system controller and looking for changes over time will give an indication of potential problems with the pack.

19 FAN/PUMP CONTROL

The BMU provides two 12V switched outputs to drive pack fans and pumps. These are provided on a standard 3-pin KK connector as used in PCs and other IT equipment. Both outputs are switched together, ie both on or both off.

The 12V to power these outputs is sourced from the contactor supply input connection. Refer to the datasheet for current and voltage ratings for these outputs.

Both connections provide a speed sensor input pin, and this is measured by the BMU and reported as an rpm number for each connection on the CAN bus telemetry. It assumes a 2 pulse per revolution sensor output, as is commonly used for most PC cooling fans.

The BMS firmware switches both outputs on when the BMS is in Run mode (once precharge has completed and the system is fully operational).

19.1 FAN/PUMP CONNECTORS

The connector used for the pump/fan outputs is a 3-way 2.54mm pitch Molex KK connector. The pinout is shown below, as viewed from the wire side – as you would look at it while inserting crimps.

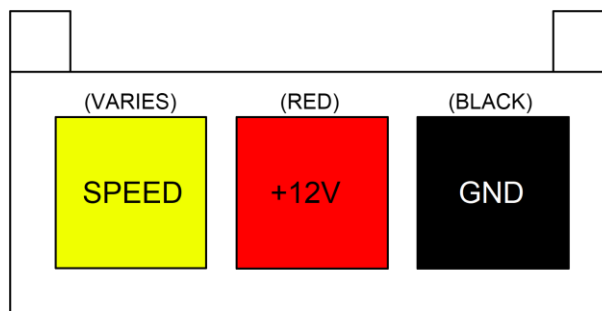

The pinout follows the standard used for PC cooling fans and pumps, as found on any computer motherboard or peripheral. Please note that the wire colours used on fans and pumps varies with each manufacturer.

20 RELAY OUTPUT

The BMU provides a voltage-free relay output to use for signalling devices in the vehicle that are not capable of receiving CAN bus data. This can be used, for example, to control the 'enable' input of a DC/DC converter or drive a relay or HV contactor. A coil suppression diode must be used if driving this type of load.

Refer to the datasheet for current and voltage ratings of the relay.

The relay is active when the BMS is in Run mode.

The connector also provides 12V and GND pins, which are sourced from the 12V contactor supply power. These can be conveniently used in conjunction with the relay to switch 12V out to a load that requires power, for instance to drive another relay, fan or contactor.

20.1 RELAY OUTPUT CONNECTOR

The connector used for the Relay output is a 6-way 4.2mm pitch Molex MiniFit Jr connector. The pinout is shown below, as viewed from the wire side – as you would look at it while inserting crimps.

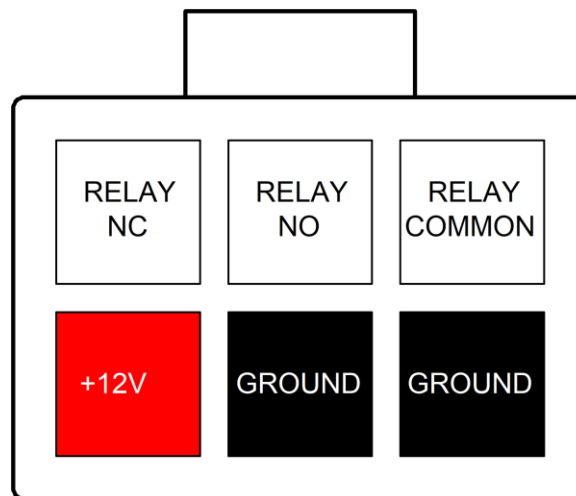

The +12V and Ground pins in this connector are wired (on the BMU PCB) to the Contactor 12V supply connector, and can be jumpered across to the relay pins to provide 12V output on relay active or inactive, switch loads to ground, etc, depending on the jumper arrangement.

The Relay pins in this connector are wired directly to a small relay on the BMU PCB. Refer to the datasheet for the ratings on this relay.

21 VEHICLE CAN BUS

21.1 CAN NETWORK TOPOLOGY

The CAN bus is structured as a linear network, with short stubs branching from 'T' connectors on the main bus backbone to each device. The CAN bus data lines must be terminated at each end of the main bus with 120 ohm resistors between the CAN-H and CAN-L signals.

In the range of Prohelion EV products, including EV Driver Controls and BMU, the CAN connections are implemented with an 'in' and an 'out' connector, therefore placing the 'T' on the device, resulting in a very short fixed-length stub on the circuit board of each device. This is ideal from a signal integrity and network performance point of view.

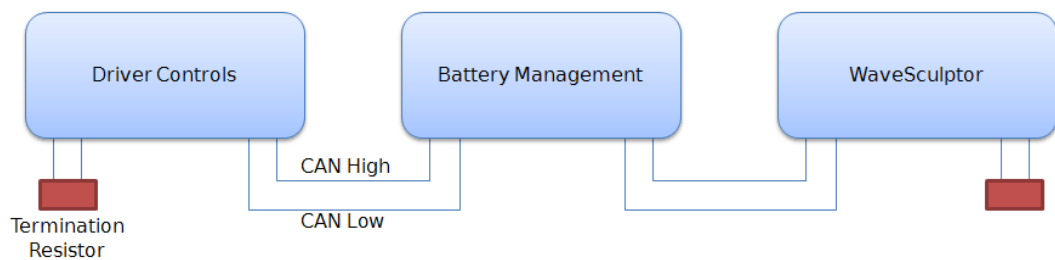

The BMU uses the vehicle CAN bus to receive operating and configuration commands and transmit telemetry, as well as a source of low-voltage DC power to operate the electronics.

21.2 CAN WIRING

The CAN data lines (CAN-H and CAN-L) must be implemented with twisted-pair wire for proper data integrity. The wire should have a characteristic impedance of 120 ohms.

Power should also be provided along the CAN cable, ideally with another twisted pair to minimise noise pickup. An overall shield can also be advantageous.

The optimal choice of cable is 7mm Devicenet CANbus 'thin' cable, with 24AWG (data) + 22AWG (power) twisted pairs and a braided shield. Using this cable will result in a robust installation, with high immunity to noise, low voltage drop in the power cable, and reliable CAN communications. Using alternative cabling will usually result in problems during operation.

21.3 VEHICLE CAN BUS CONNECTORS

The connector used on the BMU and other Prohelion devices for the CAN connection is a 6-way 3mm pitch Molex MicroFit connector. The pinout is shown below, as viewed from the wire side – as you would look at it while inserting crimps. The colours shown match those in the standard DeviceNet CAN cabling pairs.

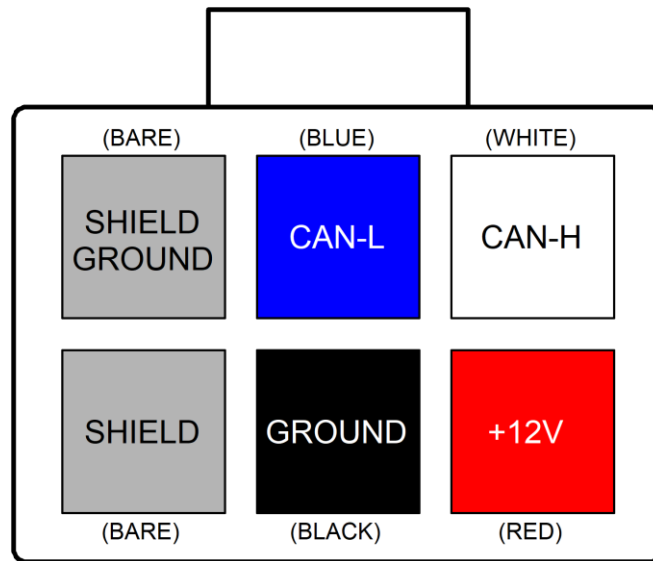

21.4 CAN SHIELDING

If the recommended braided shield is used in the cable, then terminate it to the SHIELD pin (lower-left corner on the connector) on both CAN IN and CAN OUT connectors on each device.

On **one device only** in the network, instead of using the SHIELD pin, terminate the shield to the SHIELD GROUND pin (upper-left corner on the connector) on both CAN IN and CAN OUT connectors, to ground the shield for the entire network at this single point. The usual place to do this is where power is fed into the network, typically at Prohelion's **EV Driver Controls** product.

21.5 CAN TERMINATION

To implement the required 120 Ohm termination resistor at each end of the CAN bus, plug a connector into the unused CAN connector on the last device at each end of the network with a resistor crimped into the appropriate locations.

21.6 COMMUNICATIONS

The CAN standard does not specify high-level message protocols. Prohelion devices use a custom protocol, outlined in the communication specification document for each device.

By default, each device operates at 500 kbits/second and comes programmed from the factory with a CAN base address that will allow it to work in unison with other Prohelion devices. The CAN bit rate and base address can be set with the Windows BMS configuration software.

21.7 POWER SUPPLY

The BMS electronics operate from 12V supplied on the CAN bus connector, which is switched on by the Prohelion EV Driver Controls when it is in *accessories* or *run* key switch positions.

A second high-current 12V supply connection is present for contactor and fan operating power, refer to the precharge section of this document for more details. The CAN Ground and Contactor Supply Ground must be both tied to the vehicle chassis at some point in the system.

The allowable voltage range for both supplies is 10-15V.

22 TELEMETRY VIEWING SOFTWARE

The screenshot below shows the BMS Viewing software.

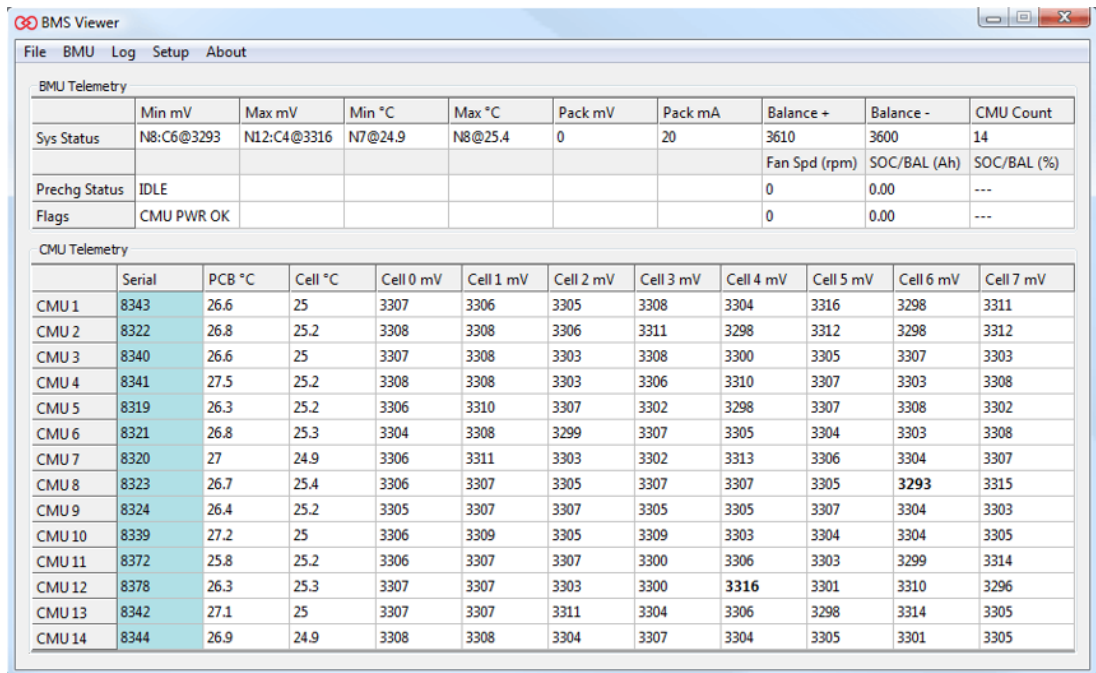

The screenshot shows the BMS Viewer application window. It contains two main data sections: BMU Telemetry and CMU Telemetry.

BMU Telemetry

	Min mV	Max mV	Min °C	Max °C	Pack mV	Pack mA	Balance +	Balance -	CMU Count
Sys Status	N8:C6@3293	N12:C4@3316	N7@24.9	N8@25.4	0	20	3610	3600	14
							Fan Spd (rpm)	SOC/BAL (Ah)	SOC/BAL (%)
Prechg Status	IDLE						0	0.00	---
Flags	CMU PWR OK						0	0.00	---

CMU Telemetry

	Serial	PCB °C	Cell °C	Cell 0 mV	Cell 1 mV	Cell 2 mV	Cell 3 mV	Cell 4 mV	Cell 5 mV	Cell 6 mV	Cell 7 mV
CMU 1	8343	26.6	25	3307	3306	3305	3308	3304	3316	3298	3311
CMU 2	8322	26.8	25.2	3308	3308	3306	3311	3298	3312	3298	3312
CMU 3	8340	26.6	25	3307	3308	3303	3308	3300	3305	3307	3303
CMU 4	8341	27.5	25.2	3308	3308	3303	3306	3310	3307	3303	3308
CMU 5	8319	26.3	25.2	3306	3310	3307	3302	3298	3307	3308	3302
CMU 6	8321	26.8	25.3	3304	3308	3299	3307	3305	3304	3303	3308
CMU 7	8320	27	24.9	3306	3311	3303	3302	3313	3306	3304	3307
CMU 8	8323	26.7	25.4	3306	3307	3305	3307	3307	3305	3293	3315
CMU 9	8324	26.4	25.2	3305	3307	3307	3305	3305	3307	3304	3303
CMU 10	8339	27.2	25	3306	3309	3305	3309	3303	3304	3304	3305
CMU 11	8372	25.8	25.2	3306	3307	3307	3300	3306	3303	3299	3314
CMU 12	8378	26.3	25.3	3307	3307	3303	3300	3316	3301	3310	3296
CMU 13	8342	27.1	25	3307	3307	3311	3304	3306	3298	3314	3305
CMU 14	8344	26.9	24.9	3308	3308	3304	3307	3304	3305	3301	3305

The top section shows data from the BMU, while the lower section shows CMU data – one row per CMU.

22.1

BMU DATA

The top row of BMU data presents the following information (left to right):

- Minimum voltage cell in the pack, and its voltage. The example shows Node (CMU) 8, Cell 6 is minimum, at 3293mV
- Maximum voltage cell in the pack, and its voltage. The example shows Node (CMU) 12, Cell 4 is maximum, at 3316mV
- Minimum temperature cell in the pack, and it's temperature
- Maximum temperature cell in the pack, and it's temperature
- Total pack voltage
- Total pack current
- Balance threshold voltage
- Balance threshold minimum voltage (balance voltage – hysteresis)
- CMU count in system

The next row shows Precharge status information on the left:

- Current state (Idle, Precharge, Run, etc)
- Contactor 12V supply voltage presence (mV on v4 or older BMUs)

The bottom row in the BMU section shows the various status flags:

- CMU Power supply OK
- Any cell OverVoltage
- Any cell UnderVoltage
- Any cell OverTemperature
- Any cell untrusted

- CMU and vehicle timeout errors

The right-hand side shows

- Fan speed for both fans
- SOC and Balance SOC in Ah
- SOC and Balance SOC in %

22.2

CMU DATA

The lower section of the program shows telemetry data from the CMUs, one row per CMU. The information shown is:

- CMU Serial number
- CMU circuit board (PCB) temperature
- CMU external (cell) temperature
- 1–8 cell voltage measurements

The data is highlighted in various ways to quickly understand the system status

- CMU serial number alternates between a white and light blue background each time a packet is received from that CMU
- Trust errors for a cell voltage have a yellow background
- Cells outside the min and max voltage limits have a red background
- Cells currently balancing have a blue background
- The minimum and maximum cells have **bold** text
- Cells not present (where the CMU has been programmed to monitor less than 8 cells) have no text, and a mid-gray background

22.3

COMMAND LINE OPTIONS

In addition to double clicking on the executable, the BMS Viewing software can also run from the command line, where certain options can be set. The supported command line options are described below:

`-s<serial number>`

This is used to specify the serial number of the BMU to connect to on the CAN bus when launched

`-f<filename>`

Specifying a filename will enable logging in the BMS_Viewer and all data will be logged to the filename.

`-l`

Using `-l` on the command line will enable logging in the BMS_Viewer and will automatically choose a filename, combining the serial number of the connected BMU device and the timestamp when the program was launched. Note that when using this option that the log file will be rolled over at midnight each day.

`-u<rate>`

This option is used to determine the logging rate. Currently one can choose between 0.2, 1, 10, and 60 second update rates.

example: `BMS_Viewer.exe -s9566 -l -u10`

23 ADDITIONAL DOCUMENTATION

Refer to **PRH67.018 BMU Wiring Diagram** PDF for details of the BMU wiring, HV contactor, and fuse layout.

Refer to **PRH67.006 Assembly Procedure** PDF for CMU wiring harness construction guidelines and recommended part numbers.

Refer to **PRH67.010 BMU Communications Protocol** for CAN packet format and specifications.

24

REVISION RECORD

REV	DATE	CHANGE
1	6 February 2020	Document creation (AJP), Website release
2	27 July 2022	Remove references to isolation testing